

ACOUSTIC  
HETEROGENEOUS VINYL

# Tapiflex Stairs

For a  
safer step



THE ULTIMATE  
FLOORING EXPERIENCE

# Versatile colours and design effects

Original designs and colours  
for a perfect match with  
Tapiflex Excellence 65.

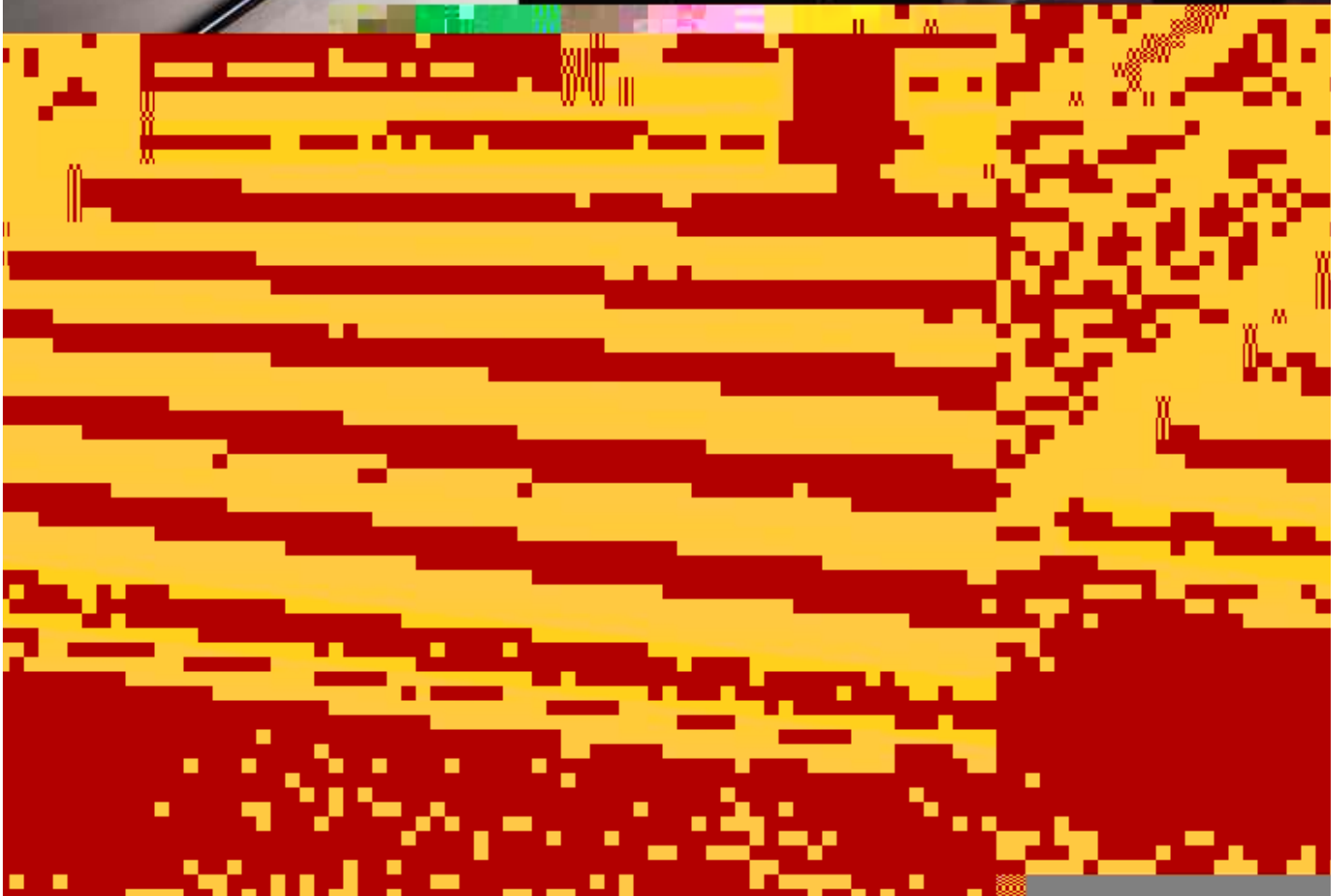

# For a safer step with Tapiflex Stairs

50%+  
natural raw  
materials

20%+  
recycled  
material

100%  
recyclable

usine  
ISO 14001  
certified  
factories

For an easier and safer access to your premises, Tarkett has developed a range of vinyl floorcoverings for stairs that meet the latest safety norms and offer unique designs.

## ■ Safety above all and a solution for any situation

Tapiflex Stairs is the result of very recent studies and developments concerning optimum safety and accessibility in public buildings, especially for the visually impaired:

- Contrastive nosing for easier detection by the visually impaired and greater visibility in poorly-lit areas. The nosing contrast varies from 40 to 70% for the entire product line, with our "Contrast+" products offering over 50% contrast,
- Visually contrasting risers, with turnkey solution, including inverted colours, stripes, etc.
- Specially designed ridges to increase slip resistance,
- Elastic foam backing to cushion impact in the event of falling and to reduce noise.

## ■ Optimal performance

- Extreme resistance to scratches and abrasion: 1mm thick pure PVC solid surface with TOPCLEAN XP™ surface treatment,
- Excellent resistance to scuffing, soiling and staining.

## ■ Unique designs

- 17 colours developed entirely from the Tapiflex range and Accent Excellence ranges, matching stairs and staircase landings perfectly: Uni or Matrix<sup>2</sup>, Wood or Concrete,
- Perfectly sized stair nosing to offer safety without compromising looks,
- Possible match with other Tarkett collections,
- Stair borders for perfect finish.

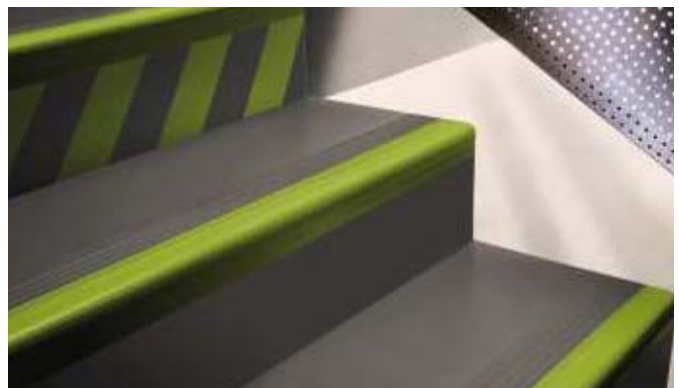

Tapiflex Stairs is part of Tarkett's choice of sustainable solutions, an integrated system that allows for balancing all the competing needs, while making choices that are truly sustainable and work together aesthetically.

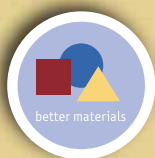

### BETTER MATERIALS

Tarkett uses renewable and natural materials whenever possible.

Increasing the level of natural and re-newable materials is the touchstone for new product development. We also regularly review the formulation of existing products to improve their natural and renewable content.



### RESOURCE STEWARDSHIP

Our production facilities are ISO 9001 and 14001 certified and are independently audited for environmental risk. Our production facilities monitor five key indicators quarterly: energy consumption, VOC emissions, waste, water consumption and recycling.



### PEOPLE-FRIENDLY SPACES

Tarkett makes flooring solutions that provide safe, healthy environments. We systematically evaluate all our flooring for its contribution to indoor air quality, and provide surface treatments that reduce the need for water, detergents and energy for cleaning.



### REUSE AND RECYCLE

We reuse recycled content in our products. We have the largest recycling operation in the flooring industry. In 2008, we diverted over 68,000 tons of flooring products from landfill.

Tapiflex and Accent Excellence are part of Tarkett's choice of sustainable solutions, an integrated system that allows for balancing all the competing needs, while making choices that are truly sustainable and work together aesthetically.

## Tactile tile for security

describes and acts as a tactile warning surface to help  
be recognized by the visually impaired. The tile should contrast  
with the surrounding floor covering to ensure clear visibility.

mm,

(with outer beveling),  
with wear indicator),

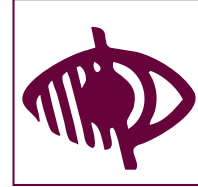

## Stair borders for a perfect finish

SB2 corners are designed to form a neat  
attractive edge around the open end of a step,  
concealing the edge of the floorcovering and  
stair edging.

### ■ Stair borders



# Optimal technical performances

For an easier and safer access to your premises, Tarkett has developed a range of vinyl floorcoverings for stairs that meet the latest norms.

## ■ Tapiflex Stairs

Tapiflex Stairs is a vinyl floorcovering incorporating a pre-formed tread riser and nosing into a one-piece floorcovering for stairs. The product has foam backing with a wear surface that is protected with TOPCLEAN XP™ PUR reinforcement. It has also a Sanitized® fungi and bacteriostatic treatment for perfect hygiene.

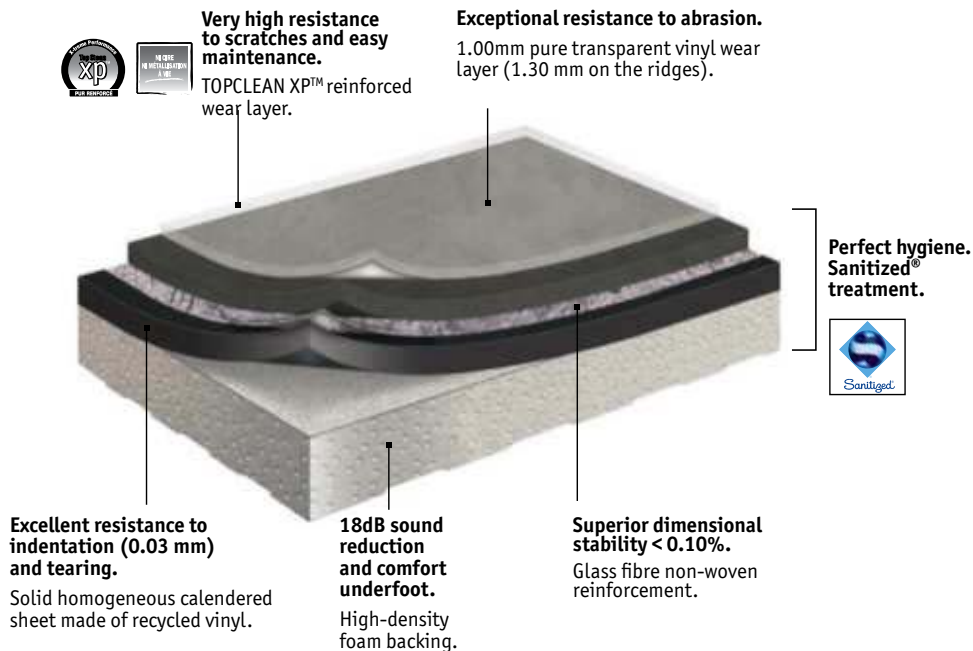





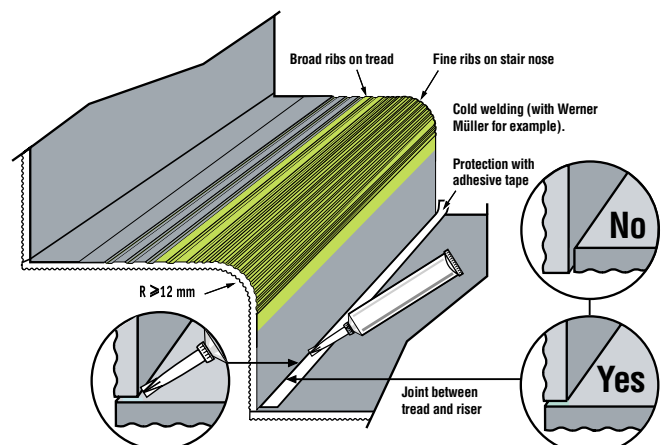
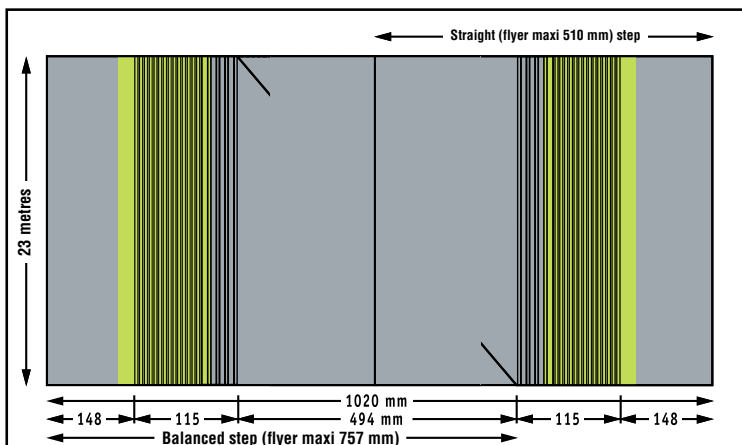















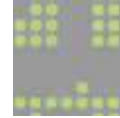







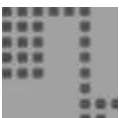













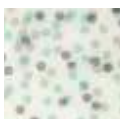







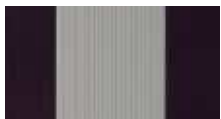
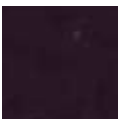















## Installation procedure













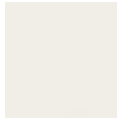

































Roll size is 102 cm x 23 m  
(102 cm is to be cut into two; giving two rolls of 51 cm x 23 m).

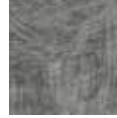

# Coordinated solutions

CONTRAST RATE		TAPIFLEX STAIRS	PERFECT MATCH WITH TAPIFLEX EXCELLENCE	POSSIBLE MATCH WITH TAPIFLEX EXCELLENCE								
48%	Phosphorescent stair nose	 3862 107 - Grey/Anis	 Warm Grey	  								
		 3862 001 - Security Grey/Anis	 Anis	     								
72% <b>Contrast +</b>		 3862 104 - Dark Grey	 Anthracite	     								
				   								
48%		 3862 108 - Orange	 Orange	     								
48%	UNI	 3862 103 - Warm Grey	 Warm Grey	     								
					   							
74% <b>Contrast +</b>		 3862 109 - Purple	 Purple	     								
67% <b>Contrast +</b>		 3862 110 - Chocolate	 Chocolate	     								
				 								
48%		 3862 111 - Grey beige	 Grey beige	     								

These combinations are given as examples.

CONTRAST RATE		TAPIFLEX STAIRS	PERFECT MATCH WITH TAPIFLEX EXCELLENCE	POSSIBLE MATCH WITH TAPIFLEX EXCELLENCE					
50%	ALU	 3862 105 - Grey		 Uni	 Uni	 Washed Oak	 Bamboo	 Cabreuva	 Matrix²
				 Concrete	 Pixel	 Flocons			
53%	WOOD	 3861 002 - Light Beech	 Light Beech	 Esquisse	 Concrete	 Coco Sisal			
74% Contrast +		 3861 003 - Rose Wood	 Rose Wood	 Light Beech	 American Oak				
57%	CONCRETE	 3861 001 - Grey	 Grey	 Oak	 Ipé	 Concrete			
69% Contrast +	ESQUISSE	 3861 015 - Dark Grey	 Dark Grey	 Esquisse	 Esquisse				
43%		 3861 017 - Medium Brown	 Medium Brown	 Washed Oak	 Washed Oak	 Esquisse	 Esquisse	 Esquisse	
41%		 3861 014 - Medium Grey	 Medium Grey	 Esquisse	 Esquisse	 Esquisse	 Steel		
59%		 3861 007 - Dark Red	 Dark Red	 Doussié	 Merbau	 Ship Deck			

